

TRAFALGAR COURT

GUERNSEY

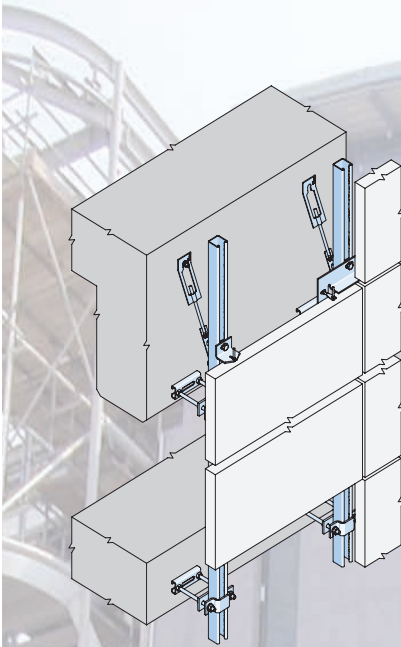

HALFEN·DEHA
YOUR BEST CONNECTIONS



To facilitate the overcladding of granite panels, a Halfen SUK Z21 Sub Structure system was utilised. This involved surface fixing of continuous vertical runs of toothed channels to the block outer leaf in conjunction with individual supports and restraints. The flexibility of this framework provided adjustability in all directions.

Installation of the cladding, which comprised some 5,993 granite panels covering an area of approximately 3,000m², was carried out by Granite Le Pelley, a sister company of R.G. Falla. The project involved Granite Le Pelley producing all the detail CAD drawings for the SUK channel configuration, whilst Halfen produced the detail sheets for individual fixings. The cladding contractor also produced over 1,600 granite detail sheets and more than 50 elevation and plan drawings for this complex building.

A development for Landmark Securities, Trafalgar Court, Guernsey, has been constructed by R.G. Falla using twin-leaf block walls along with cut and polished granite cladding. The double skin block wall construction was adopted to provide a fast track wind and watertight building prior to the application of 40 mm thick cladding.

Client:
Landmark Securities

Architect:
Lovell Ozane & Partners

Engineer:
Mouchel & Partners

Main Contractor:
R G Falla

Stone Installer:
Granite Le Pelley

System Installer:
Granite Le Pelley



HALFEN·DEHA

YOUR BEST CONNECTIONS

Halfen Limited Humphrys Road Woodside Estate Dunstable LU5 4TP
Tel: 08705 316 300 Fax: 08705 316 304
Email: info@halfen.co.uk Web: www.halfen.co.uk